



# AFO LUX

## AFOLUX Series

Affordable Luxury For You

7"~12" Fanless All-in-one Panel PC



### Maximize your business potential



The streamline AFOLUX all-in-one panel PC with stable wireless LAN connectivity and a wide range of mounting options can easily be implemented in a diverse range of applications to fully maximize your business potential.



# AFOLUX All-in-one Panel PC

Maximize your business potential

## AFL-07A-LX

- 7" embedded fanless panel pc with AMD LX-800 CPU  
LX-800 CPU
  - 1.Resolution:800\*480
  - 2.Brightness(cd/m<sup>2</sup>):220
  - 3.Touch Screen
  - 4.Audio speakers inside
- 256/512 MB memory support
- Complete I/O support with 2xRS232 COM ports, 2xUSB 2.0 and dual LAN support
- 802.11 b/g wireless antenna inside
- The best choice for Thin Client, Windows® CE 5.0 and Windows® XP Embedded

### Vehicle Interior Device

- Truck PC
- Real-time delivery checking

### General Computing

- PC based testing center
- Distance learning

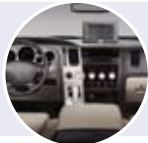
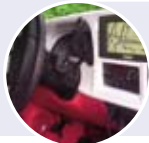

## AFL-08A-LX

- 8.4" embedded fanless panel pc with AMD LX-800 CPU
  - 1.Resolution:800\*600
  - 2.Brightness(cd/m<sup>2</sup>):220
  - 3.Touch Screen
  - 4.Audio speakers inside
- 256/512 MB memory support
- Complete I/O support with 2xRS232 COM ports, 2xUSB 2.0 and dual LAN support
- 802.11 b/g wireless antenna inside
- The best choice for Thin Client, Windows® CE 5.0 and Windows® XP Embedded

### Industrial Applications

- Plant environment monitoring system
- Factory automation platform
- Manufacturing shop flow
- Equipment and device control

### Home and Building Automation

- Digital surveillance system
- E-home platform
- Home IA control terminal



## AFL-12A-LX

- 12" embedded fanless panel pc with AMD LX-800 CPU
  - 1.Resolution:1024\*768
  - 2.Brightness(cd/m<sup>2</sup>):450
  - 3.Touch Screen
  - 4.Audio speakers inside
- 256/512 MB memory support
- Complete I/O support with 2xRS232 COM ports, 2xUSB 2.0 and dual LAN support 1024x768 high resolution
- 802.11 b/g wireless antenna inside
- The best choice for Thin Client, Windows® CE 5.0 and Windows® XP Embedded

### Self-Service Kiosk

- Receptionist kiosk in hotel and business premises
- Self registration terminal in hospital and airport.
- Interactive photo kiosk
- Video rental kiosk
- Ticket vending machine for transportation use
- Self-service POS terminal
- Price-check machine



# Always Connected

## IEI's network advantage

## Features

### Wireless Anywhere

If you are still looking for stable wireless LAN connectivity, the integrated PIFA antenna on the AFOLUX ensures you can have an uninterrupted wireless connection. PIFA type antennas can receive high-quality, uniform signals in any location from all directions without any signal degradation or impedance and are the most efficient on the market today. The inverted F-design generates an omni-directional signal field through the exceptionally uniform 3D signal sphere. PIFA enhances transmission and reception through the special cubic structure to ensure optimum wireless performance.



### Dual LAN Support

To provide you with the "Always connected" advantage, IEI has implemented dual LAN support along side the PIFA wireless technology. Dual independent 10/100 Mbps Ethernet design reduces the hazard of network collisions and crashes or virus infection. With the AFOLUX series, the network connection between the AFOLUX and the server never fails.

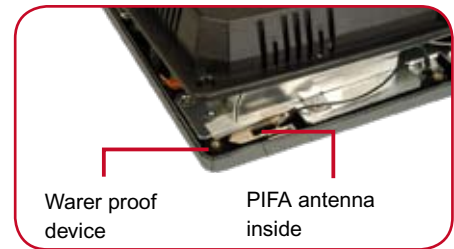

## Best Reliability

## Features

### Fanless System

The AFOLUX series is designed with an AMD LX-800 platform. The AMD Geode LX 800 generates less heat than other processors but maintains an above-average performance enabling a fanless design. A fanless design reduces the failure caused by fans and extends the operation life of the device.

### Rugged Mechanism Design

The AFOLUX is directly mounted internally to a metal main frame rather than a fragile plastic cover. The ABS/PC (Acrylonitrile Butadiene Styrene/Polycarbonate Alloy) makes the AFOLUX case stiffer, more solid and more durable than if conventional material were used.

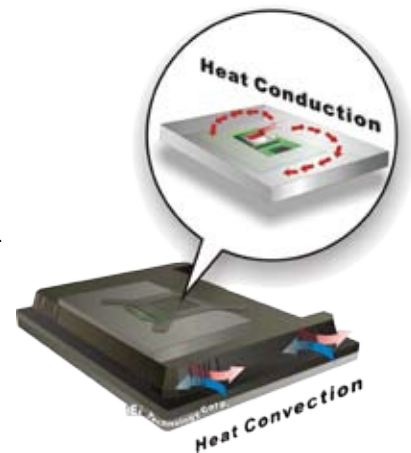

### Anti-Vibration Protection

IEI AFL-12A is equipped with a drive kit to increase the resistance of the hard drive to side shocks and vibrations. The drive kit extends the drive life cycle in environments such as vehicles and marine applications.

### IP 64 Dustproof and Waterproof Front Panel

The AFOLUX front panel is IP 64 compliant. IP 64 compliance guarantees the front panel is dustproof and water-proof. The AFOLUX front panel can withstand any industrial environment where dust and drizzle is encountered.



# IQ Mounting

## Features

IEI IQ mount design allows the AFOLUX series to be easily integrated into a diverse variety of applications. The ARM design for industrial control, panel mount for kiosk device, wall mount for e-home terminal, stand design for thin client application and shop flow for manufacturing management. The AFOLUX series' intelligent mounting design brings more value to you.



### Panel Mounting



**Panel Mount Kit**  
AFLPK-07  
AFLPK-08  
AFLPK-12



### Wall Mount Kit



**Wall Mount Kit**  
AFLWK-07  
AFLWK-08  
AFLWK-12

## 12.1" LCD - 1024x768 high resolution & 450 nits high brightness **Features**

### Affordable Luxury Multimedia Applications

The AFOLUX-12A is superior multimedia effects for diverse applications. Integration into advertising devices is especially effective since the 1024x768 high resolution screen provides crystal clear images. The high brightness panel enables the AFOLUX to be used outdoors in strong sunlight as an information kiosk.

For better sound track effects, the AFOLUX-12A has two integrated speakers. The speakers provide great sound quality for arcade games where enhanced sound effects for improved satisfaction is essential.

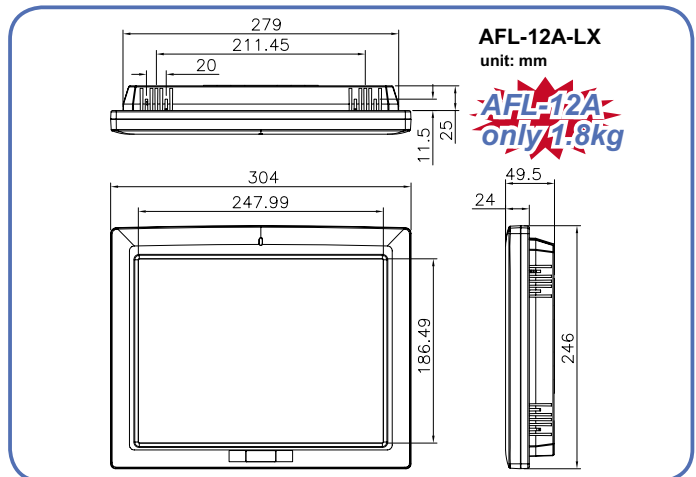
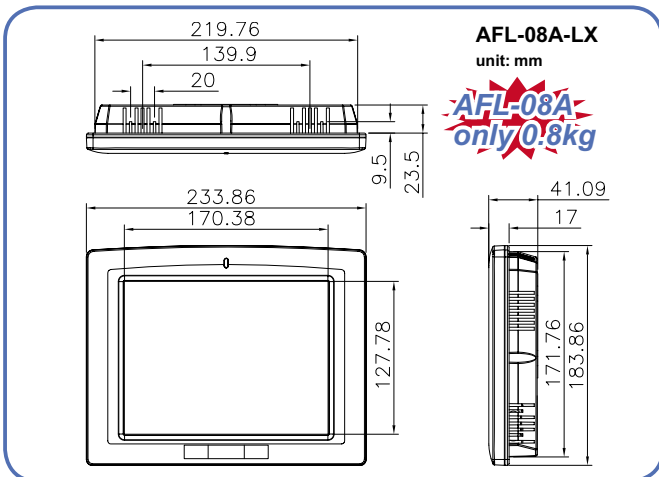
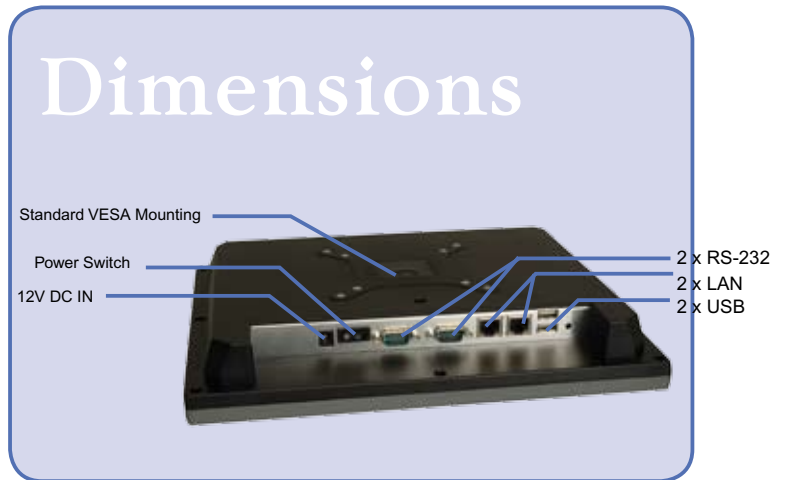
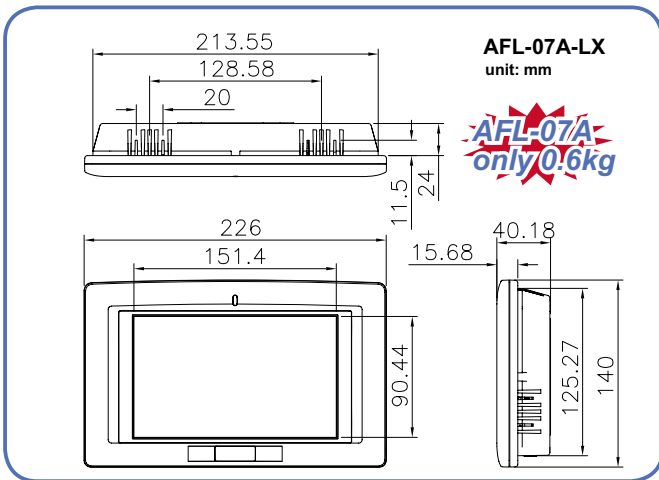

# All-in-one Panel PC - LX

## Embedded OS Support

IEI provides optional pre-installed Windows XP Embedded or Windows CE 5.0 turnkey solutions tailored for the AFOLUX series. These turnkey solutions have one Compact Flash memory card with either Windows XP Embedded or Windows CE 5.0 pre-installed, one Windows XP Embedded or Windows CE 5.0 license, and one CD that contains all related SDK (Software Development Kit) and user manuals.



**AFLCF-07-LX-CE**  
**AFLCF-08-LX-CE**  
**AFLCF-12-LX-CE**

128 MB



**Includes:**

- Windows CE 5.0 OS image with license
- Thin Client turnkey solutions
- SDK



**AFLCF-07-LX-XPE**  
**AFLCF-08-LX-XPE**  
**AFLCF-12-LX-XPE**

1 GB



**Includes:**

- Windows XPE OS image with license
- Thin Client turnkey solutions

## Thin Client Technology

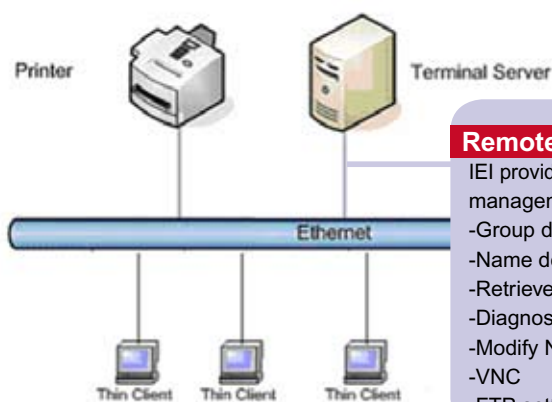

**Remote Management Tool**

- IEI provides you with a free remote management tool to
- Group device
  - Name devices
  - Retrieve device information
  - Diagnose device
  - Modify Network settings
  - VNC
  - FTP settings

AFOLUX also provides built-in Thin Client Technology in embedded OS turnkey solutions. The thin client technology enables an AFOLUX to access Microsoft Windows-based applications and web-based applications. These applications actually live and run on Microsoft Terminal Service servers, so an AFOLUX can act as a thin client terminal and remotely execute legacy applications, Windows-based SCADA systems, and Windows applications such as word processors, spreadsheets, and database queries.

### Advantages of Thin Client Technology

- Reduced hardware costs
- Reduce software costs
- Reduced maintenance costs
- Centrally controlled resources
- Security and protection
- Client crash prevention

### Applications

- KIOSK
- Thin Client POS
- Logistics
- Database system terminals
- OA and IT



## Specifications



**AFL-07A**  
only 0.6kg



**AFL-08A**  
only 0.8kg



**AFL-12A**  
only 1.8kg

Model	AFL-07A-LX	AFL-08A-LX	AFL-12A-LX
LCD Size	7"	8.4"	12.1"
Max Resolution	800 * 480	800 * 600	1024 * 768
Brightness (cd/m <sup>2</sup> )	220	220	450
Contrast Ratio	400:1	500:1	700:1
LCD Color	262K	262K	262K
Pixel Pitch (mm)	0.1905(H) x 0.1905(V)	0.213(H) x 0.213(V)	0.240(H) x 0.240(V)
Viewing Angle (H-V)	140/100	130/110	160/160
SBC Model	AFLMB-LX800	AFLMB-LX800	AFLMB-LX800
CPU	AMD LX800-500Mhz	AMD LX800-500Mhz	AMD LX800-500Mhz
Chipset	AMD LX800 + AMD CS5536	AMD LX800 + AMD CS5536	AMD LX800 + AMD CS5536
RAM	Maximum memory supported 1GB ( SODIMM X 1 ) Supports for DDR333 / 400Mhz	Maximum memory supported 1GB ( SODIMM X 1 ) Supports for DDR333 / 400Mhz	Maximum memory supported 1GB ( SODIMM X 1 ) Supports for DDR333 / 400Mhz"
I/O Ports	2 x RS232 COM Port 2 x RTL8100C for 10/100Mbps 2 x USB 2.0 1 x Power Switch 1 x Reset Button	2 x RS232 COM Port 2 x RTL8100C for 10/100Mbps 2 x USB 2.0 1 x Power Switch 1 x Reset Button"	2 x RS232 COM Port 2 x RTL8100C for 10/100Mbps 2 x USB 2.0 1 x Power Switch 1 x Reset Button
SSD	CFII	CFII	CFII
Audio	2 x AMP 1.5W internal speakers	2 x AMP 1.5W internal speakers	2 x AMP 1.5W internal speakers
Expansion	1x Mini PCI ( Wireless Lan 802.11b/g Module )	1x Mini PCI ( Wireless Lan 802.11b/g Module )	1x Mini PCI ( Wireless Lan 802.11b/g Module )
HDD Drive Bay	N/A	N/A	1 x 2.5" HDD bay
Construction Material	ABS Plastic & Aluminum	ABS Plastic & Aluminum	ABS Plastic & Aluminum
LED Function	1 x LED on Front Panel for Power ON/OFF	1 x LED on Front Panel for Power ON/OFF	1 x LED on Front Panel for Power ON/OFF
Mounting	Panel / Wall / Rack / Stand / Arm mounting	Panel / Wall / Rack / Stand / Arm mounting	Panel / Wall / Rack / Stand / Arm mounting
Front Panel Color	Gray	Gray	Gray
Dimension (WxHxD) (mm)	226(W) x 140(L) x 41(D)	234(W) x 184(L) x 42(D)	304(W) x 246(L) x 50(D)
Operating Temperature (°C)	0~50°C	0~50°C	0~50°C
StorageTemperature (°C)	-20°C ~60°C	-20°C ~60°C	-20°C ~60°C
Vibration	-5~17Hz 0.1 double amplitude displacement -17~640 Hz 1.5G acceleration peak to peak	-5~17Hz 0.1"" double amplitude displacement -17~640 Hz 1.5G acceleration peak to peak	-5~17Hz 0.1 double amplitude displacement -17~640 Hz 1.5G acceleration peak to peak"
Shock	10G acceleration peak to peak (11ms)	10G acceleration peak to peak (11ms)	10G acceleration peak to peak (11ms)
Net Weight	0.6/kg	0.8 / Kg	1.8 / Kg
IP Level(front panel)	IP 64	IP 64	IP 64
Safety	Complies with UL, CE and CCC	Complies with UL, CE and CCC	Complies with UL, CE and CCC
EMC	Complies with CE and FCC Class B	Complies with CE and FCC Class B	Complies with CE and FCC Class B
Touch Screen	Resistive Type 4-Wire (touch controller IC is on board)	Resistive Type 4-Wire (touch controller IC is on board)	Resistive Type 5-Wire (touch controller IC is on board)
Power Adapter	-P/N:63000-UP0451E12P81L-RS -45W -Input:90~260VAC@ 50/60Hz -Output:12VDC	-P/N:63000-UP0451E12P81L-RS -45W -Input:90~260VAC@ 50/60Hz -Output:12VDC	-P/N:63000-UP0451E12P81L-RS -45W -Input:90~260VAC@ 50/60Hz -Output:12VDC
Power Requirement	12VDC	12VDC	12VDC
Power Consumption	20W	20W	29W

# Ordering Information



## AFL-07A 7" Slim Outlook Model

- AFL-07A-LX/WT-R/256MB  
7" fanless panel pc with AMD LX-800 CPU, 256MB DDR RAM, wireless module and touch screen, RoHS
- AFL-07A-LX/WT-R/512MB  
7" fanless panel pc with AMD LX-800 CPU, 512 MB DDR RAM ,wireless module and touch screen, RoHS



## AFL-08A 8.4" Optimal Screen Size Model

- AFL-08A-LX/WT-R/256MB  
8.4" fanless panel pc with AMD LX-800 CPU, 256MB DDR RAM, ,wireless module and touch screen, RoHS
- AFL-08A-LX/WT-R/512MB  
8.4" fanless panel pc with AMD LX-800 CPU, 512MB DDR RAM, ,wireless module and touch screen, RoHS



## AFL-12A 12.1" High Resolution Model

- AFL-12A-LX/WT-R/256MB  
12.1" fanless panel pc with AMD LX-800 CPU, 256 MB DDR RAM,wireless module and touch screen, RoHS
- AFL-12A-LX/WT-R/512MB  
12.1" fanless panel pc with AMD LX-800 CPU, 512 MB DDR RAM,wireless module and touch screen, RoHS

## Packing list

- 1 x Screw Kit
- 1 x Power Cable
- 1 x Power Adapter
- 1 x Jumper Pack
- 1 x User Manual - CDROM

## Option

	AFL-07A-LX	AFL-08A-LX	AFL-12A-LX
Panel mounting kit	AFLPK-07	AFLPK-08	AFLPK-12
Wall mounting kit	AFLWK-07	AFLWK-08	AFLWK-12
Rack mounting	AFLRK-07	AFLRK-08	AFLRK-12
OS: WIN CE 5.0	*AFLCF-07-LX-CE	*AFLCF-08-LX-CE	*AFLCF-12-LX-CE
OS: WIN XPE	*AFLCF-07-LX-XPE	*AFLCF-08-LX-XPE	*AFLCF-12-LX-XPE

\* Note: Include - CF card, OS image with WINCE or XPE license and IEI Thin Client software package  
 CF card capacity with 

CE 5.0	: 128MB
XPE	: 1GB

# AFO LUX

All-in-one Panel PC



### Headquarters

**IEI Technology Corp.**  
 TEL : +886-2-86916798 FAX : +886-2-66160028  
 sales@ieiworld.com www.ieiworld.com  
 No. 29, Jhongsing Rd., Sijih City, Taipei County, 221, Taiwan

### America-United States

**IEI Technology USA Corp.**  
 TEL : +1-562-690-6677 FAX : +1-562-690-0898  
 sales@usa.ieiworld.com www.usa.ieiworld.com  
 515 N. Puente St., Brea, CA 92821

### China

**Armorlink SH Corp.**  
 TEL : +86-21-54429000 FAX : +86-21-54429100  
 sales@ieiworld.com.cn www.ieiworld.com.cn  
 No.515, Shenfu Road, Minhang District, Shanghai, China