

# ConneXium Ethernet Gateway TSXETG100

Installation Guide  
63230-319-207A1

02/2006

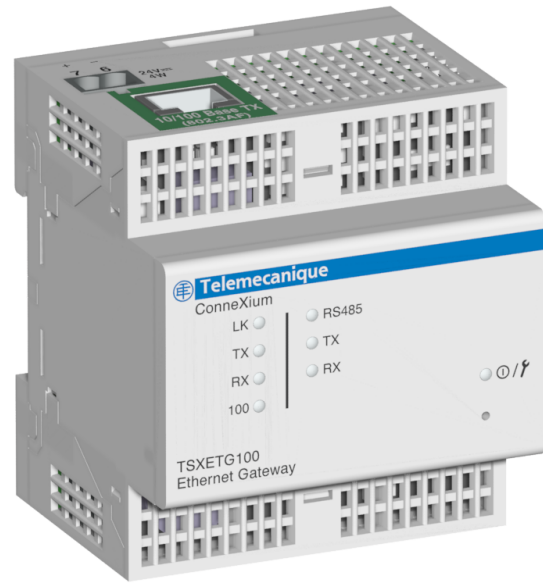

## SAFETY PRECAUTIONS



### HAZARD OF ELECTRIC SHOCK, EXPLOSION, OR ARC FLASH

- Only qualified workers should install this equipment. Such work should be performed only after reading this entire set of instructions.
- NEVER work alone.
- Before performing visual inspections, tests, or maintenance on this equipment, disconnect all sources of electric power. Assume that all circuits are live until they have been completely de-energized, tested, and tagged. Pay particular attention to the design of the power system. Consider all sources of power, including the possibility of backfeeding.
- Apply appropriate personal protective equipment (PPE) and follow safe electrical practices. For example, in the USA, see NFPA 70E.
- Turn off all power supplying the equipment in which the ETG is to be installed before installing and wiring the ETG.
- Always use a properly rated voltage sensing device to confirm that power is off.
- Beware of potential hazards, wear personal protective equipment, and carefully inspect the work area for tools and objects that may have been left inside the equipment.
- The successful operation of this equipment depends upon proper handling, installation, and operation. Neglecting fundamental installation requirements may lead to personal injury as well as damage to electrical equipment or other property.

Failure to follow these instructions will result in death or serious injury.

## INTRODUCTION

### Box Contents

- ETG unit and connectors
- Registration card
- Installation guide
- Technical Library CD-ROM
- Technical support contact sheet

### Additional Resources

**Documentation and Firmware:** Go to [www.telemecanique.com](http://www.telemecanique.com), select Products > Products index > Systems and architectures > ConneXium.

## Quick Start Checklist

- Mount the unit.
- Determine the control power method and connect the power.
- Configure the Ethernet communications settings with a web browser (using an Ethernet crossover cable) or with HyperTerminal (using a null modem cable, which is included in the TCSEAK0100 configuration kit [sold separately]).
- Configure the serial ports.
- Configure the device list.
- Wire the serial ports.

## DESCRIPTION

1. 24 Vdc control power connection
2. 10/100BaseTx (802.3af) connection
3. LEDs:

#### Ethernet:

- LK: Active link
- TX: Transmitting data
- RX: Receiving data
- 100: Link speed. 100 Mb = ON, 10 Mb = OFF

#### Serial:

- RS485: RS485 mode = ON, RS232 mode = OFF
- TX: Transmitting data
- RX: Receiving data

#### Power/Status

4. DIN rail release
5. Reset button (press to reboot the ETG; no data is lost)
6. RS485 connection
7. Dip switches
8. RS232 connection

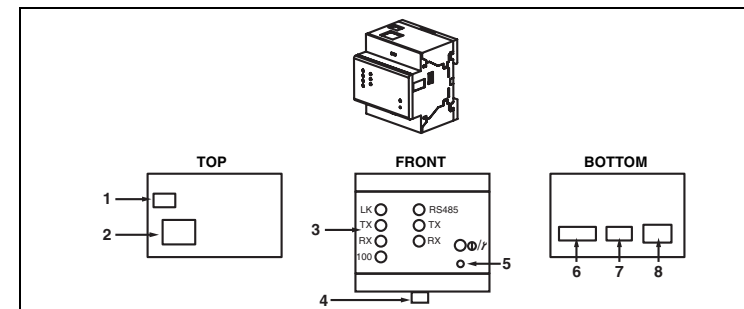

## INSTALLATION

### Dimensions

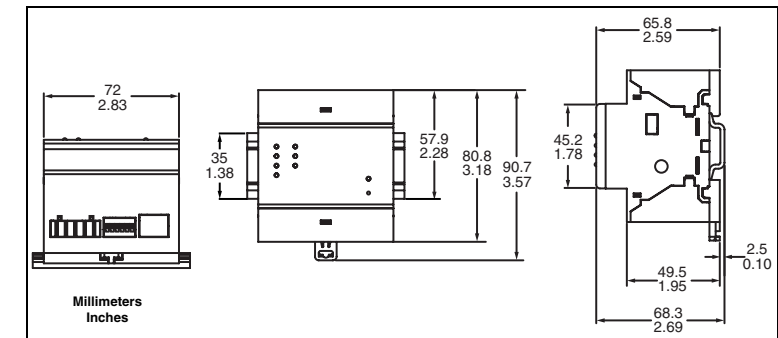

### DIN Rail Mounting and Removal

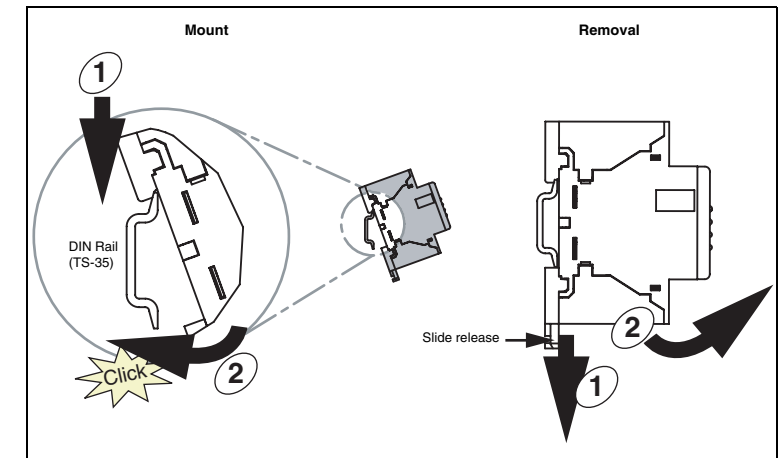

## Powering the ETG

### Power-over-Ethernet (PoE [IEEE 802.3af])

The ETG supports PoE (IEEE 802.3af), allowing the ETG to be powered over an Ethernet connection. Use either configuration A or B below:

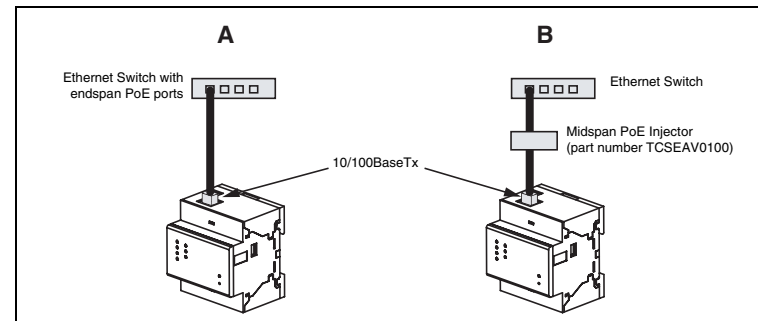

**NOTE:** Use a PoE injector that fully complies with the IEEE 802.3af standard for active midspan devices, such as the TCSEAV0100 from Schneider Electric.

### 24Vdc Control Power

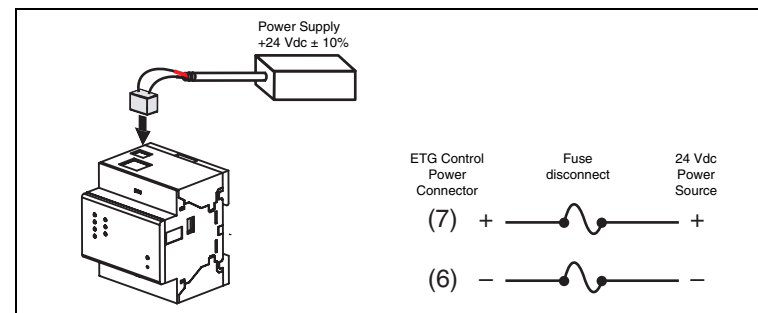

## Ethernet Configuration

Before configuring the ETG, obtain a unique static IP address, subnet mask, and default gateway address from your network administrator. Use a Web browser or HyperTerminal to configure the ETG with the information obtained from your network administrator.

### Ethernet Setup Using a Web Browser

1. Disconnect your computer from your network.  
**NOTE:** After disconnecting from your network, your computer should automatically use the default IP address 169.254.###.### (### = 0 to 255) and the default subnet mask 255.255.0.0. If the IP address is not automatically configured, contact your network administrator to set up a static IP address.
2. Connect an Ethernet crossover cable from the ETG to the computer.

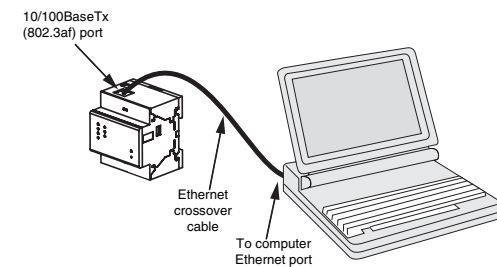

**NOTE:** See "Powering the ETG" for powering options.

3. Start Internet Explorer (version 6.0 or higher).
4. In the **Address** text box, type 169.254.0.10, then press Enter.
5. Type **Administrator** for your user name, type **Gateway** for your password, then click **OK**. User names and passwords are case sensitive.
6. Click **Setup**.
7. If the "Ethernet & TCP/IP" page isn't open, click **Ethernet & TCP/IP** in the menu on the left side of the page.
8. Select the frame format and media type (see Table 1 for a description of each option).
9. Enter your IP address, subnet mask, and default gateway address assigned to your ETG by your network administrator (see Table 1 for a description of each option), then click **Apply**.
10. Reconnect your computer to your network. If you assigned a static IP address to your computer in step 1, you must restore your computer's original settings before reconnecting to your network.

Table 1: ETG Ethernet and TCP/IP Settings

Option	Description	Setting
Frame Format	Used to select the format for data sent over an Ethernet connection.	Ethernet II, 802.3 SNAP <b>Default:</b> Ethernet II
Media Type	Used to define the physical Ethernet connection.	<ul style="list-style-type: none"> <li>• 10T/100Tx Auto</li> <li>• 10BaseT-HD</li> <li>• 10BaseT-FD</li> <li>• 100BaseTX-HD</li> <li>• 100BaseTX-FD</li> </ul> <b>Default:</b> 10T/100Tx Auto
IP Address	Used to enter the static IP address of the ETG. <b>NOTE:</b> If you enter an IP address that is already in use, you will be prompted to select a different IP address.	0.0.0.0 to 255.255.255.255 <b>Default:</b> 169.254.0.10
Subnet Mask	Used to enter the Ethernet IP subnet mask address of your network.	0.0.0.0 to 255.255.255.255 <b>Default:</b> 255.255.0.0
Default Gateway	Used to enter the gateway (router) IP address used for wide area network (WAN) communications.	0.0.0.0 to 255.255.255.255 <b>Default:</b> 0.0.0.0

### Ethernet Setup Using HyperTerminal

1. Attach a null modem cable (see below).

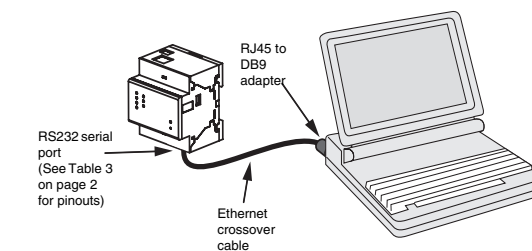

**NOTE:** The RJ45 to DB9 adapter and the Ethernet crossover cable are included in the TCSEAK0100 configuration kit (sold separately).

2. Click **Start > Run**, then type *hypertrm*.
3. In the **Name** text box, type a name for the new connection (for example, *ETG config*), then click **OK**.
4. In the **Connect using** drop-down list box, select the computer COM port you will be using, then click **OK**.

5. Set the COM properties as follows: Bits per second = 19200, Data bits = 8, Parity = None, Stop bits = 1, and Flow control = None.
6. Click **OK**.
7. Start the ETG Setup Utility:
  - a. Cycle power or press the reset button on the ETG.
  - b. While the green Power/Status LED blinks rapidly, press Enter on the computer keyboard to access the setup utility. See Table 2 for a description of the setup options.  
**NOTE:** The Power/Status LED stops blinking after 5 seconds.

Table 2: ETG Setup Utility Options

Option	Description	Setting
1	Used to select the language for the current HyperTerminal session.	English, French, Spanish, German <b>Default:</b> English
2	Used to select the format for data sent over an Ethernet connection.	Ethernet II, 802.3 SNAP <b>Default:</b> Ethernet II
3	Used to enter the static IP address of the ETG. <b>NOTE:</b> If you enter an IP address that is already in use, you will be prompted to select a different IP address.	0.0.0.0 to 255.255.255.255 <b>Default:</b> 169.254.0.10
4	Used to enter the subnet mask of your network.	0.0.0.0 to 255.255.255.255 <b>Default:</b> 255.255.0.0
5	Used to enter the default gateway (router) IP address used for wide area network (WAN) communications.	0.0.0.0 to 255.255.255.255 <b>Default:</b> 0.0.0.0
6	Used to define the physical Ethernet connection.	<ul style="list-style-type: none"> <li>• 10T/100Tx Auto</li> <li>• 10BaseT-HD</li> <li>• 10BaseT-FD</li> <li>• 100BaseTx-HD</li> <li>• 100BaseTx-FD</li> </ul> <b>Default:</b> 10T/100Tx Auto
7	Saves the settings and exits the setup utility.	—

## Serial Configuration

1. Start Internet Explorer.
2. In the **Address** text box, type the IP address assigned to your ETG, then press Enter.
3. Type **Administrator** for your user name, type **Gateway** for your password, then click **OK**.
4. Click **Serial Port** or **Device List** as appropriate and proceed to the sections below.

### Serial Port

1. Click **Serial Port**.
2. Select the mode, physical interface, transmission mode, baud rate, and parity for the serial COM port.  
*NOTE: Attached serial devices must have the same baud rate, parity, and wiring mode settings. If you are using RS485, set the mode according to whether your daisy chain is 2-wire or 4-wire.*

Parameter	Options	Default Setting
Mode	Master, Slave	Master
Physical Interface	RS485 4-wire, RS485 2-wire, RS232	RS485 2-wire
Transmission Mode	Modbus RTU, Modbus ASCII	Modbus RTU
Baud Rate	2400, 4800, 9600, 19200, 38400, 56000 <sup>U</sup> , 57600 <sup>U</sup>	19200
Parity	None, Even	Even
① RS232/Modbus ASCII only.		

3. If Mode is set to Slave, enter a unique IP address for each remotely connected device. See the User's Guide 63230-319-211 for more information about the slave mode.
4. Click **Apply** to save changes.

### Device List

For daisy-chain devices on the COM port:

- In Master mode, Modbus devices do not have to be defined in the Device List, but it helps you manage your system.

To set up the Device List for the ETG:

1. Click **Device List**.
2. Select the number of viewable devices (1 to 128). The default number of devices is eight.
3. In Master mode, enter the **Local ID** for each attached device on the daisy chain. In Slave mode, enter the **Local ID**, **Remote ID**, and select the **Connection** for each device that needs to be remotely connected.
4. Click **Apply**.

## RS485 Wiring

*NOTE: For surge protection, we recommend connecting the shield wire directly to an external earth ground at a single point. For instructions on wiring common Schneider Electric devices, see the wiring instructions on the ETG100 Technical Library CD.*

### 4-wire Devices

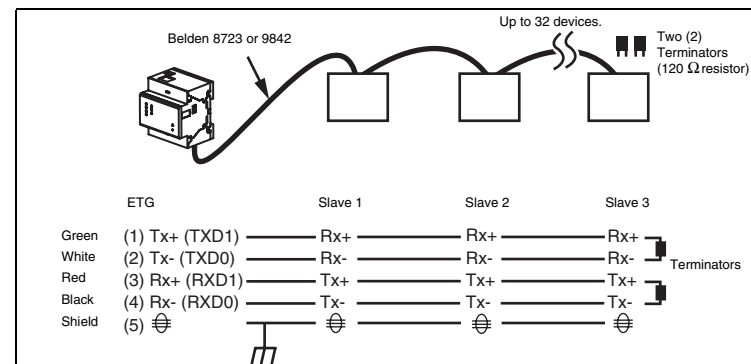

*NOTE: The color code shown is for Belden 8723. The color code for Belden 9842 is Blue/White (Tx+), White/Blue (Tx-), Orange/White (Rx+), and White/Orange (Rx-).*

### 2-wire Devices

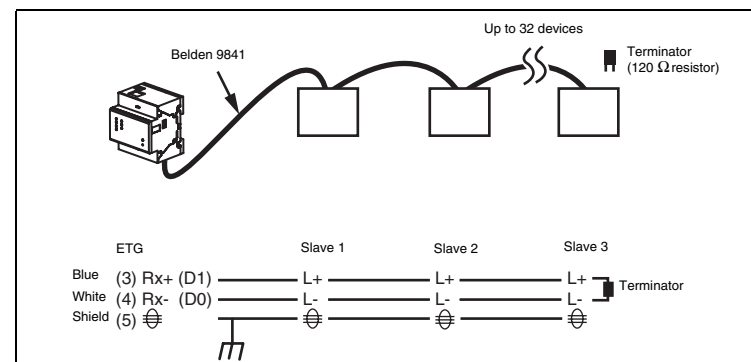

## Daisy Chain Maximum Distances

Baud Rate	Max. distance for 1–16 devices	Max distance for 17–32 devices
1200	10,000 ft (3,048 m)	10,000 ft (3,048 m)
2400	10,000 ft (3,048 m)	5,000 ft (1,524 m)
4800	10,000 ft (3,048 m)	5,000 ft (1,524 m)
9600	10,000 ft (3,048 m)	4,000 ft (1,219 m)
19200	5,000 ft (1,524 m)	2,500 ft (762 m)
38400	5,000 ft (1,524 m)	1,500 ft (457 m)

*NOTE: This table is only to be used as a guide.*

## RS485 Biasing and Termination

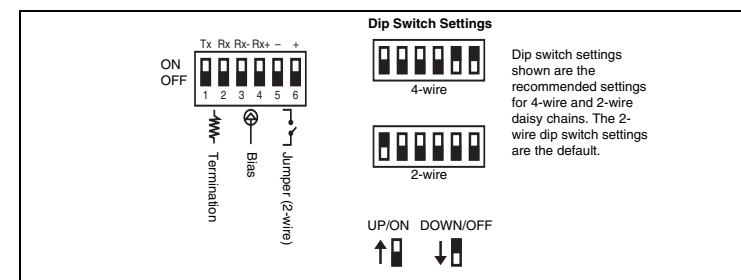

## RS232 Serial Port

*NOTE: The ETG pinout for the RJ45 (RS232) is compliant with the EIA/TIA-561 standard. To ensure proper connections with other Schneider Electric products, examine the wiring for each device. See the wiring instructions on the ETG100 Technical Library CD for more information, or contact your local Schneider Electric support representative.*

The RS232 port is used to configure the ETG network parameters, and also can be used for serial communication using Modbus. The ETG RS232 port is wired as a data terminal equipment (DTE) device and uses a standard RJ45 connector.

*NOTE: An RJ45 to DB9 adapter is included in the TCSEAK0100 configuration kit (sold separately) for use with an Ethernet crossover cable.*

**Table 3: RS232 Pin Assignments (EIA/TIA-561 for RJ45)**

Pin No.	Description
Pin 1	Data Set Ready
Pin 2	Received Line Signal Detector (Data Carrier Detect)
Pin 3	Data Terminal Ready
Pin 4	Signal Ground
Pin 5	Received Data
Pin 6	Transmit Data
Pin 7	Clear To Send
Pin 8	Request To Send

## SPECIFICATIONS

Control Power Input	
Power-over-Ethernet	Class 3
Operating Input Range	24 Vdc (±10%) sourced by Class 2 rated power supply
Burden, maximum	4 W
Isolation	1.5 kV
Environmental	
Ambient Operating Temperature	0° to +60°C
Storage Temperature	-40°C to +85°C
Humidity Rating	5–95% Relative Humidity (non-condensing) at +55°C
Pollution Degree	Class 2
Physical	
Weight	6 oz. / 170 g
Dimensions	Height (3.18 in. / 80.8 mm), Width (2.83 in. / 72 mm), Depth (2.59 in. / 65.8 mm)
Enclosure	IP30
Regulatory/Standards Compliance for Electromagnetic Interference	
Emissions (radiated and conducted)	EN 55022 / EN 55011 / FCC Class A
Immunity for Industrial Environments:	EN 61000-6-2
Electrostatic Discharge	EN 61000-4-2
Radiated RF	EN 61000-4-3
Electrical Fast Transients	EN 61000-4-4
Surge	EN 61000-4-5
Conducted RF	EN 61000-4-6
Power Frequency Magnetic Field	EN 61000-4-8
Regulatory / Standards Compliance for Safety	
International (CB Scheme)	IEC 60950
USA	UL 508 / UL 60950
Canada	cUL (complies with CSA C22.2, #60950)
Europe	EN 60950
Australia / New Zealand	AS/NZS 60950
Other Regulatory / Standards Compliance	
Europe	CE
Transparent Ready	B15

## MAINTENANCE AND TROUBLESHOOTING

### Maintenance

The ETG does not require maintenance, nor does it contain any user-serviceable parts. If the ETG requires service, contact your local sales representative for help. Refer to the technical support contacts provided in the shipping carton for a list of support phone numbers by country. Do not open the ETG enclosure; this will void the product warranty agreement.

### Diagnostics

The Diagnostics page served by the ETG, displays diagnostic data that may be helpful in troubleshooting network problems. This page also contains information about your specific ETG, including the serial number, manufacturing date, and media access control (MAC) address. Clicking the Reset button on this page clears all cumulative counters.

*NOTE: This page will show accumulated readings since the ETG was last activated. If power to the ETG is lost, all values reset to zero.*

## Troubleshooting

# ⚠ DANGER

**HAZARD OF ELECTRIC SHOCK, EXPLOSION, OR ARC FLASH**

- This equipment must be installed and serviced only by qualified personnel.
- Qualified persons performing diagnostics or troubleshooting that require electrical conductors to be energized must comply with and follow safe electrical work practices. For example, in the USA, see NFPA 70E.

**Failure to follow these instructions can result in death or serious injury.**

Problem	Possible Cause	Solution
Power/Status LED is not lit.	Source power is not applied or is not stable. LED is burned out.	Apply power or check power source. Check to see if other LEDs operate properly.
Ethernet link LED is not lit.	Proper link is not established.	Make sure the proper cable is used and connected. Make sure the proper media type is selected in the ETG Communications setup configuration.
Power/Status LED repeats a four blink-pause pattern	The IP address that the ETG was assigned is being used by another networked device.	Assign a new IP address to the ETG or to the conflicting device. <i>NOTE: When a duplicate IP address is detected, the ETG resets its specified IP address to the default IP address. When the ETG detects the conflict no longer exists, it will use the specified IP address.</i>
Cannot browse the ETG.	Incorrect network configuration.	Verify all IP parameters are correct. Verify ETG receives requests (ping ETG by going to DOS prompt and typing "ping" and the ETG IP address, e.g., <b>ping 169.254.0.10</b> ).
Forgot administrator password.		Verify all browser internet options connections settings are correct. Call your local sales representative for assistance.

www.schneider-electric.com  
www.telemecanique.com

This product must be installed, connected, and used in compliance with prevailing standards and/or installation regulations. As standards, specifications, and designs change from time to time, please ask for confirmation of the information given in this publication.

© 2006 Schneider Electric. All Rights Reserved.

